

Lucalox™ PSL

PhotoSynthesis Light (PSL) Lamps with improved reliability specifically designed for Horticulture applications using GE's XO technology.

Lucalox™ PSL Clear Tubular 230V

400W, 600W and 750W

Lucalox™ PSL Clear Tubular 400V

600W and 750W

- **Superb Performance and High Reliability**
 - GE's advanced sodium resistant ceramic helps eliminate early failures to give a rated service life* of 10,000 hours for the Lucalox™ PSL products.
 - In order to achieve maximum performance, GE recommends lamp replacement when the Rated Service Life* is reached.
 - The lamp uses extra rugged monolithic arc tubes equipped with GE Reliable Starting Technology which provides continuous high performance.
- **High Xenon-Fill gas delivers:**
 - extra light and PAR (Photosynthetically Active Radiation) output.
 - more resistance to mains voltage fluctuations.
- **Zirconium gettering system gives:**
 - improved PAR maintenance that drives constant and uniform plant growth
- **Bulk Pack**
 - all lamps are available in a specially designed bulk pack for easy installation of lamps on site. This pack can also be used to transport used lamps to the recycling centers. Sturdy recycled cardboard, with carry handles, with no fee or extra charge for the pack.
- **Top Marking**
 - with the increased use of 400V systems, these lamps will be clearly marked with the voltage and wattage on the top of the lamp to ensure correct installation
- The diameter of the frame wire in the lamp has been minimised to reduce shading in the installation without affecting the robustness of the lamp.

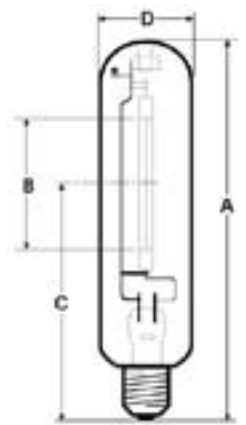

Figure 1.

Physical Data

Watts	A Max. Length (mm)	B Arc Gap (mm)	C LCL (mm)	D Diameter (mm)	Cap	Bulb Glass	Packed Mass (g)	Operating Position	Standard Product Code (12)	Bulk Product Code (63)
Lucalox™ PSL - PhotoSynthesis Light, Clear Tubular										
LU400W/PSL	283	85	175	48	E40/45	Hard	210	Universal	17106	44304
LU600W/PSL	283	117	168	48	E40/45	Hard	220	Universal	17107	44305
LU750W/PSL	293	130	178	51	E40/45	Hard	230	Universal	17108	44306
LU400V/600W/PSL	283	117	168	48	E40/45	Hard	220	Universal	43440	43439
LU400V/750W/PSL	293	130	178	51	E40/45	Hard	230	Universal	43438	43437

*Rated Service Life: Number of aging hours during lamps provide consistent and high performance of operation.



Lamp Survival and PAR Maintenance

Rated service lamp life & PAR maintenance is based on laboratory tests of a large number of representative lamps under controlled conditions, including operation at 3 hours per start on ballasts having specified electrical characteristics. Reliability is also tested in large scale field tests in greenhouses.

The following conditions can reduce average lamp life and lumen maintenance:

- frequent on/off switching
- high line voltage
- excessive vibration
- high ambient temperature within the fixture
- non-compatible ballast and ignitor characteristics.

Rated Service Life

The survival of individual lamps or particular groups of lamps depends on these system conditions (see Lamp Survival graph).

For cost-of-light calculations involving these lamps, it is suggested to replace both the 230V and the 400V type PSL lamps after 10,000 hours burning.

PAR Maintenance

Under the same controlled conditions, initial reference PAR value refers to the lamp light output after 100-hours burning. Due to variations in systems and service conditions (in particular the burning cycle and the operating system), actual lamp performance can vary from the reference PAR ratings.

Photometric Data

Watts	100 hour Lumens	100 hour PAR $\mu\text{mol}/\text{sec}$
Lucalox™ PSL – Clear Tubular		
LU400W/PSL	56,500	725
LU600W/PSL	90,000	1100
LU750W/PSL	112,000	1350
LU400V/600W/PSL	85,000	1150
LU400V/750W/PSL	104,000	1415

Photometric data is quoted in a horizontal orientation operating from a nominal ballast at rated supply volts.

Typical Lamp Survival

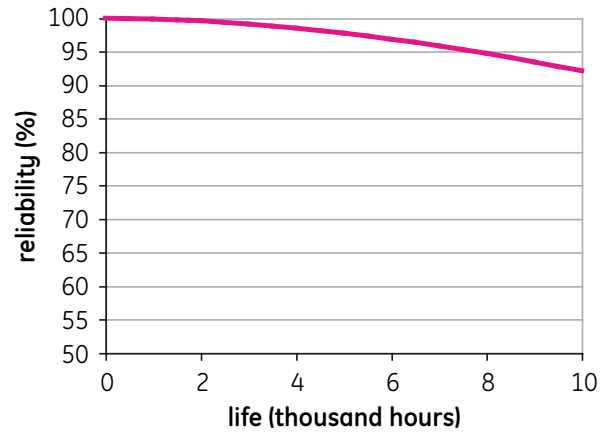

Typical PAR Maintenance

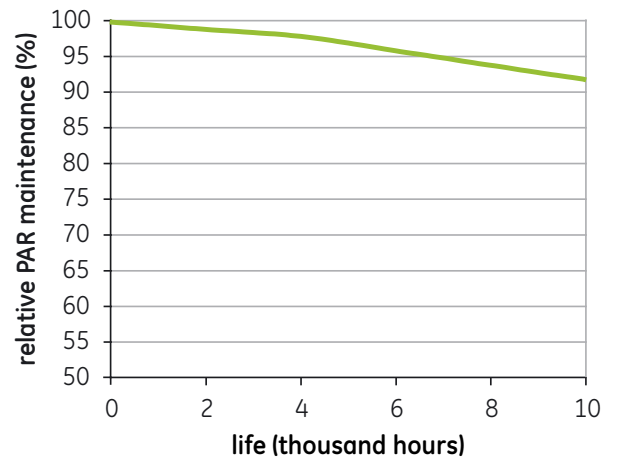

Spectral Power Distribution – 230V type PSL lamps

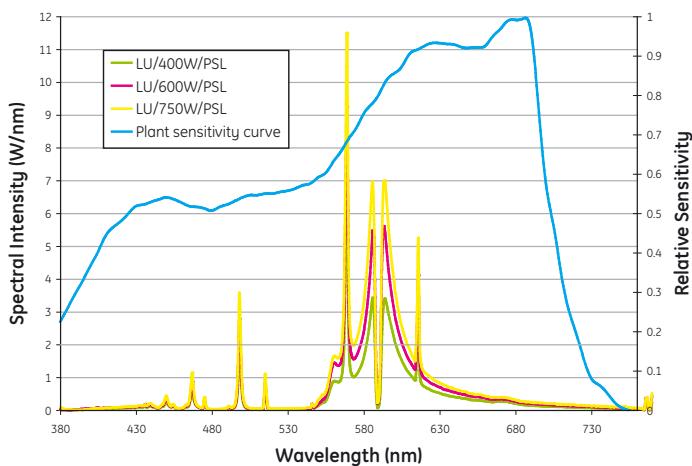

Spectral Power Distribution – 400 V type PSL lamps

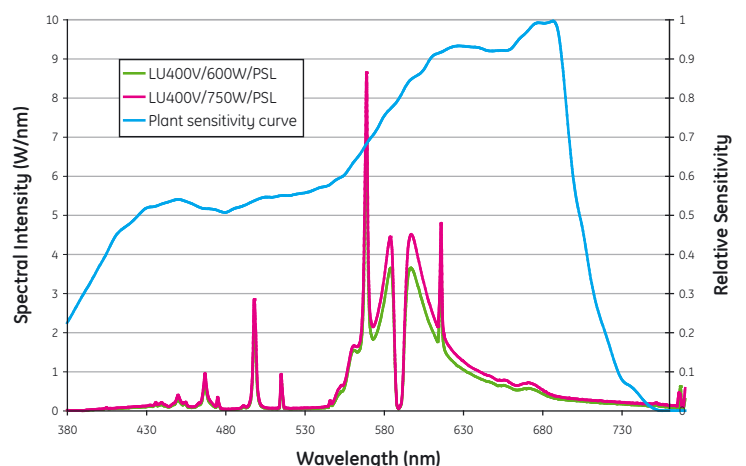

Electrical Data

Data is based on a nominal lamp operating from a nominal choke (reactor) ballast with power factor correction. Supply power is based on a typical commercially available ballast.

Run-Up Characteristics

The graph shows typical run-up characteristics for a LU600W/PSL lamp. The time needed for the light output to reach 90% of the final value is determined by the supply voltage and ballast design. Typical values are:

Watts	400	600	750
Run-Up (minutes)	5	4	3

Hot Restrike Time

All ratings restrike within 5 minutes. This occurs when the lamp has cooled to a temperature at which the starting aid can re-establish the arc. The new solid state starting aid is integrally bonded to the arc tube for shorter restrike time, and improved reliability — no moving parts or welds.

Supply Voltage

Lamps are suitable for supplies in the range 220V to 250V 50/60 Hz (230V PSL) or 390 V to 420 V 50 Hz (400V PSL) for appropriately rated series choke (reactor) ballasts. Supplies outside these ranges require a transformer (conventional, high reactance or CWA) to ensure correct lamp operation. Lamps start and operate at 10% below the rated supply voltage when the correct control gear is used. In order to maximise lamp survival and PAR maintenance, the supply voltage and ballast design voltage should be within $\pm 3\%$. Supply variations of $\pm 5\%$ are permissible for short periods only. This may be achieved by measuring mean supply voltage at the installation and selecting ballasts with appropriate settings. Lamps should be used with gears rated to lamp nominal supply voltage.

Ballasts

It is essential to use a ballast appropriate to the supply voltage at the luminaire. Typical wiring diagrams for control circuits incorporating "Superimposed" or "Impulser" ignitor and choke (reactor) ballast are shown. Refer to actual choke and ignitor manufacturers' data for terminal identification and wiring information.

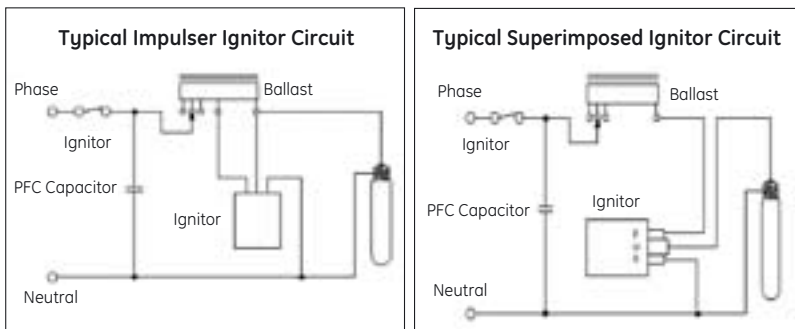

Lamp Data (Nominal)

Watts	Volt (V)	Current (A)	Power (W)
Lucalox™ PSL – Clear Tubular			
LU400W/PSL	110	4.3	420
LU600W/PSL	115	6.0	615
LU750W/PSL	115	7.4	755
LU400V/600W/PSL	200	3.6	620
LU400V/750W/PSL	205	4.4	765

Depending on systems conditions, lamp power can vary by $\pm 2.5\%$

Typical Run-up Characteristics

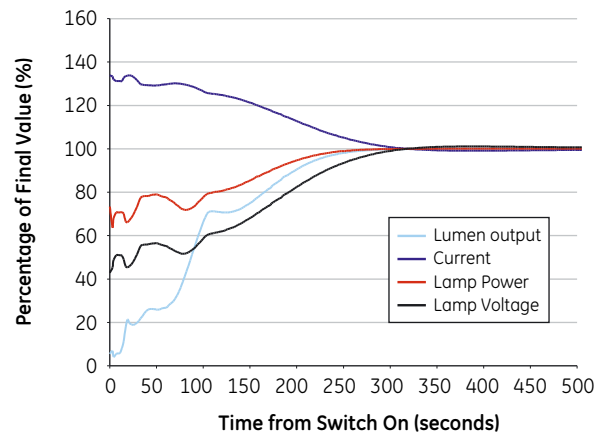

Mains Voltage variations-230V PSL

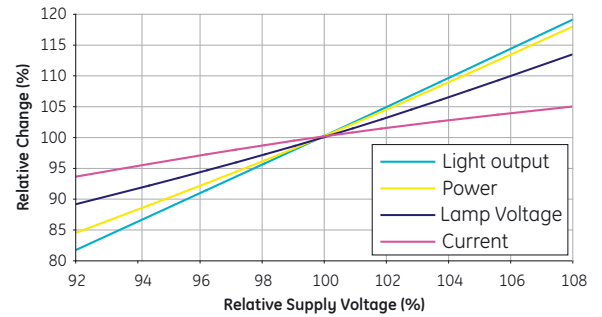

Mains Voltage variations-400V PSL

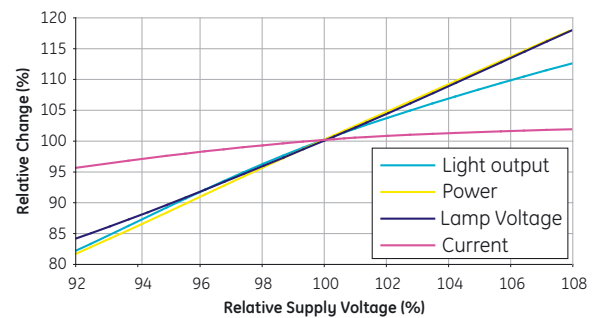

Guidance For Luminaire Manufacturers

Lamp Operating Temperature Limits

Watts	400	600	750
Clear Tubular			
Max. Bulb Temperature	400 °C	410 °C	410 °C
Max. Cap Temperature	250 °C	250 °C	250 °C

Luminaire Voltage Rise

To maximize lamp life it is essential that luminaires are designed so that when lamps are enclosed lamp voltage rise does not exceed the following values:

Watts	400	600	750
Clear Tubular			
Voltage Rise (V)	12	12	12

Ballasts

To achieve correct lamp starting, performance and life, it is important that the lamp and ballast are compatible and suitably rated for the supply voltage at the luminaire. Lucalox™ PSL lamps comply with IEC62035 (HID Lamp Safety) standards. Ballasts used to operate these lamps should comply with ballast standards IEC60922 & IEC60923 and incorporate adequate overload protective measures to ensure that safety is maintained under abnormal lamp end-of-life rectification conditions as prescribed by IEC62035 and draft changes to luminaire standard EN60598-1. Ballast thermal protection is recommended for providing adequate protection.

Ballast Voltage Adjustment — For series choke (reactor) ballasts a single additional tapping 10V (230V line voltage) or 20 V (400V line voltage) above the rated supply voltage are recommended. This will ensure lamps are not over loaded due to excessive supply voltage.

PFC Capacitors for Choke (Reactor) Circuits

Power Factor Correction is advisable in order to minimise supply current and electricity costs. For 220-250V supplies, 250V nominal voltage rated capacitors with ±10% capacitance tolerance are recommended. For 400 V supplies 450 V voltage rated capacitance are recommended as follows:

Watts	LU400W/ PSL	LU600W/ PSL	LU750W/ PSL	LU400V/ 600W/PSL	LU400V/ 750W/PSL
Ballast impedance (V/A)	40.9	29.7	24.2	87.5	71
PFC Capacitor (µF)	50	60	60	20	22.5

Ignitors

Ignitors should comply with specifications IEC60926 and IEC60927 and have starting pulse characteristics as follows:

Watts	Min. Pulse Voltage (kV) ⁽¹⁾	Max. Pulse Voltage (kV) ⁽²⁾	Min. Pulse Width (µs) ⁽³⁾	Min. Pulse Repetition Rate ⁽⁴⁾
400	3.3	5.0	1.95	1 / cycle
600	4.0	5.0	1.95	1 / cycle
750	3.3	5.0	1.95	1 / cycle

1. When Loaded with 100 pF min. 3. At 90 % peak voltage
2. When Loaded with 20 pF max. 4. Pulse Phase Angle: 60-90°el and/or 240-270° el.

Recommended ignitors for the 400 V line voltage systems:
Tridonic ZRM-ES/B 400, Bag Turgi 400 NI 2000
UE Philips SN 88 T5

Timed Ignitors

Use of a “timed” or “cut-out” ignitor is not a specific requirement, but it is a good optional safety feature for the installation. The timed period must be adequate to allow lamps to cool and restart when the supply is interrupted briefly (see “Hot Re-strike Time”).

A period of 10 minutes continuous or intermittent operation is recommended before the ignitor is automatically switched off. Commercially available 10/11 minute timed ignitors are suitable.

Cable Between Ignitor And Lamp

Cables connected between the lamp and a superimposed ignitor “Lp” terminal, or the ballast when using an impulser ignitor, must be rated at a minimum 50/60Hz voltage of 1000V. Mineral-insulated cables are not suitable for connecting the lamp to the control gear.

To achieve good starting superimposed ignitors must be adjacent to the luminaire. Cable capacitance of wiring between the ignitor “Lp” terminal and the lamp should not exceed 100pF (<1 metre length) when measured to adjacent earthed metal and/or other cables, unless otherwise stated by the ignitor manufacturer. When using impulser type ignitors, longer cable lengths between ballast and lamp are normally permissible. Limits for particular ignitors are available directly from the ignitor manufacturer.



GE Lighting is constantly engaged in the global quality process. A statistical quality system designated SIX SIGMA is applied across the board in all areas of the company from manufacturing through to sales.